

CC37

CHECK VALVE

3/8" UP TO 690 BAR 10,000 PSI

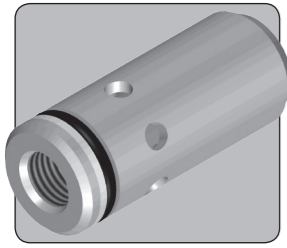

The CC37 is a 3/8" nominal bore cartridge check valve. It will allow flow in one direction, and blocks flow in the opposite direction. It may also be referred to as a non-return valve.

The valve uses sealed poppet technology to give virtually zero leakage with liquids and gases.

- Check or Non-Return valve
- Cartridge design ideal for installation in manifold systems
- Internally threaded for easy extraction
- Stainless steel construction
- Sealed poppet design
- Virtually zero leakage
- Suitable for liquid or gas
- Suitable for use with air, nitrogen, sweet natural gas, mineral oils, water glycols, water and sea water
- Suitable for many other media, contact us for advice
- Various seal options available

Specifications

BASIC MODEL NUMBER

CC37

SYMBOL



MAX WORKING PRESSURE (LIQUID)

690 bar
(10,000 psi)

MAX WORKING PRESSURE (GAS)

345 bar
(5,000 psi)

CV (FLOW CAPACITY)

1.3

FLUID

Liquids and Gases
See materials section

TEMPERATURE RANGE

See Product Selector opposite
and Technical Data section

NOMINAL SIZE

3/8"

CRACKING PRESSURE

0.1 - 0.3 bar
(2 - 5 psi)

WEIGHT

0.05 kg
(0.11 lb)

Specifications may change without notice

Materials

316 stainless steel with 302 stainless steel spring, and acetal. The spring is inconel for SWD variants.

The standard valve is designed for use with air, nitrogen, sweet natural gas, mineral oil, water glycols and plain water, and may also be used with a wide variety of media compatible with the materials of construction.

! The standard valve has Viton® seals. Further seal options are available via the Product Selector. Compatibility with the working fluid at the operating temperature must be considered.

Typical Performance

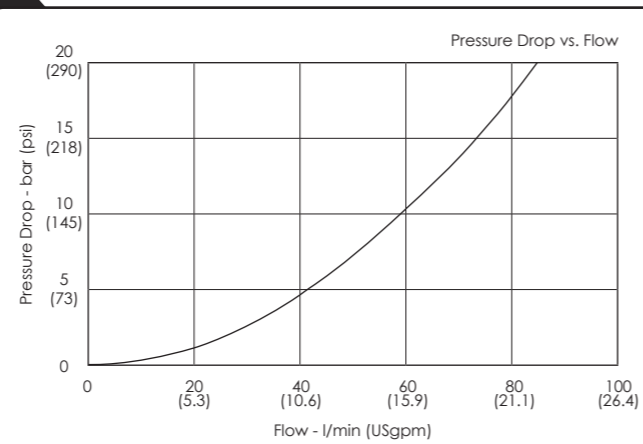

Typical performance based on water

Installation Diagram

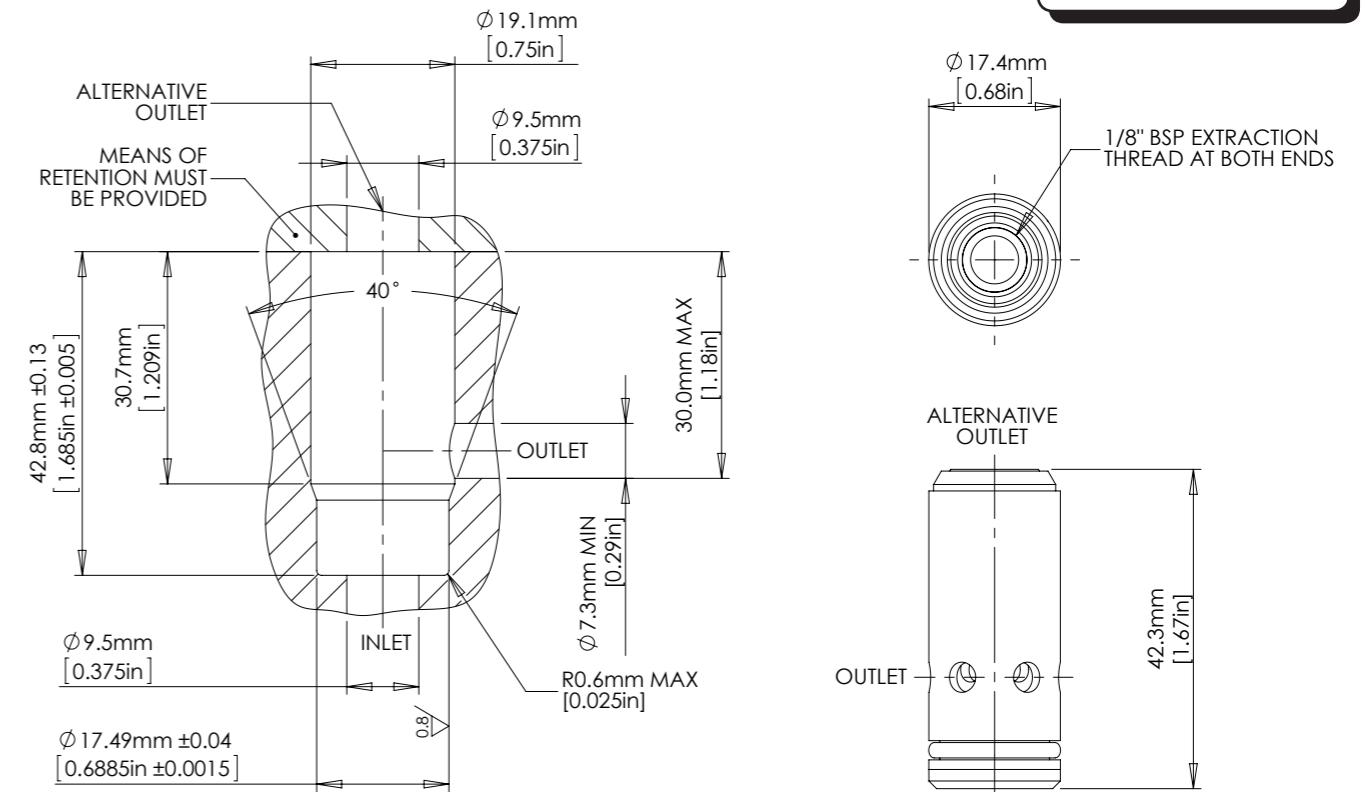

NOTE: CONTACT BIS FOR DETAILS OF CAVITY WITH THREADED PLUG RETENTION.

Product Selector

CC37 - NBR - SWD - 10K

VALVE TYPE	SEAL OPTIONS	VALVE OPTIONS	MAX WORKING PRESSURE
CC37	<p>Leave blank for Viton® seals -10°C to +120°C</p> <p>NBR Nitrile seals -30°C to +105°C</p> <p>EP EPDM seals -45°C to +120°C</p> <p>KLZ Kalrez® seals -25°C to +120°C</p> <p>HNBR Hydrogenated Nitrile seals -20°C to +120°C</p> <p>Further seal options are available on request</p>	<p>Leave blank if not required</p> <p>SWD Materials compatible with sea water</p>	<p>10K 690 bar (10,000 psi) Liquid</p> <p>345 bar (5,000 psi) Gas</p> <p><i>The maximum working pressure of an installed valve is dependent on the housing design. Contact us for advice if in doubt regarding the suitability of any housing design</i></p>

These valves are not internally serviceable. Seal kits containing external seals are available on request

For a seal kit add SK at the end of the model code



Catalogue also available on digital media
Visit our website for a full online search facility
www.bisvalves.co.uk



BIS VALVES
The Specifier's Catalogue