

DIAPHRAGM AIR ACTUATOR Type: A2

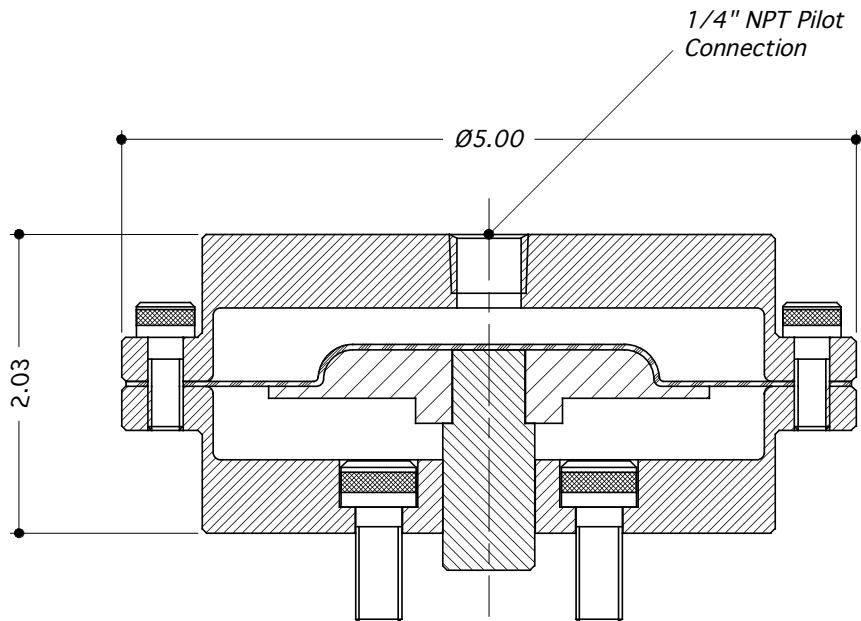

- Low Pressure operation.
- Stainless Steel (316 / 1.4404)
- All dimensions in inches.



Technical Specification Note:-

* The Maximum Pilot Pressure is for the above Actuator design only. Different applications may limit the Maximum Pilot Pressure due to the design of the Valve Body being used. Check with the individual Valve Body technical specification sheets for details.

TECHNICAL SPECIFICATION		Ordering Example
Actuator Type:	A2	A2
Pilot Port Size:	1/4"	
Thread Form: (Pilot supply)	NPT (Taper)	
Maximum Pilot Pressure: *	150 psi	
Diaphragm Material:	Nitrile (with Nylon fabric reinforcement)	
Dry Weight (kg)	0.5	
Working Temperature Range:	-10°C to +80°C	